

Coakley Middle School

Norwood Public Schools

Middle School Building Committee

September 12, 2022

Agenda

August 15, 2022

- ◆ **Votes to approve: meeting minutes, VIP, Compass Amendment 2**
- ◆ **CMR Selection Update**
VOTE to approve CMR recommended by the Selection Subcommittee
- ◆ **Project Update**
CD phase & schedule

September 12, 2022

- ◆ **Votes to approve: meeting minutes & VIP**
- ◆ **CMR Introductions**
WT Rich presentation
- ◆ **Project Update**
Document Development
Schedule
Budget



COAKLEY
MIDDLE
SCHOOL



Ai3 Architects, LLC
Compass Project Management

VOTE to Approve: Meeting Minutes

August 15, 2022 Meeting Minutes

VOTE to Approve: Vendor Invoice Package

Vendor	Invoice	Amount
Compass Project Management	CPM 87-26	\$29,852.50
Ai3 Architects	0018B-2002.00	\$546,689.25
Ai3 Architects	0009E-2002.00	\$2,006.40
Ai3 Architects	0009E-2002.00	\$41,907.60
Ai3 Architects	0009E-2002.00	\$4,500.000
Ai3 Architects	0009E-2002.00	\$5,920.00

TOTAL INVOICES THIS MONTH: \$630,875.75

W.T. Rich Company: ABOUT

- ◆ Founded in 1968 by Walter Rich
- ◆ Massachusetts Public Market Specialist
- ◆ Predominately MGL Chapter 149A
- ◆ Focused Approach → 8 to 10 Projects
- ◆ Challenging Sophisticated Projects
- ◆ **Client Driven**
 - *Performance*
 - *Reliability*
 - *Integrity*
 - *Fairness*

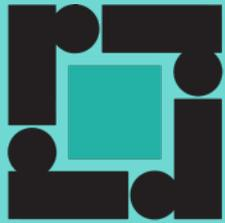

W.T. RICH COMPANY



FIRM EXPERIENCE

Past 20 Years



King Open School

100%
MA Public Projects



Smith Elementary School

90%
MGL Chapter 149A



Manchester Memorial Elementary School

80%
School Construction



Boston Collegiate Charter School

50%
Occupied Construction



Clark Avenue Middle School

16 Projects
Sustainability



Dr. Martin Luther King, Jr. School

14 Projects
MSBA Experience

SUSTAINABILITY

- ◆ W.T. Rich is the only CM to construct three LEED Platinum certified public projects in Massachusetts
- ◆ First Net Zero emissions school in the state
- ◆ Second school in the country **LEED Platinum Version 4**
- ◆ Four NZE projects underway



Dr. Martin Luther King, Jr. School

- 60 Geothermal Wells
- 100% of the roof covered by Solar PV Panels
- Rapidly Renewable Materials
- LEED Platinum Certified
- Net Zero Ready



King Open School/Community Complex

- 190 Geothermal Wells
- 3,000 Solar PV Panels
- First School in Massachusetts to Achieve Net Zero Carbon Emissions
- LEED Platinum V4

Project Team: W.T. Rich

KEY
Preconstruction
Construction



TEAM SUPPORT

 Richard Marks <i>Mechanical Estimator</i>	 Paul French <i>Electrical Estimator</i>	 Paula Guity <i>DEI/HR Manager</i>	 Bridgette Petillo <i>Project Administrator</i>
--	--	--	---

Value Added Differentiators: For Coakley

Best Budget Outcome

Meet GMP and maximize what you get for your money!

School/Community Impact

Maximize safety and minimize disruption

Most Relevant Experience

Ch.149A, Public Schools, Occupied, Sustainability

Exceptional Team

Outstanding track record and references

Project Update: DOCUMENT DEVELOPMENT

◆ Incorporate Value Management items

◆ Continued coordination

◆ Increase drawings & details to further define design & prepare for construction

DD SUBMISSION



REMOVE GYPSUM
WALL BOARD (GWB)
SOFFITS & CEILINGS

DRAWINGS SUBMITTED:
- Civil
- Landscape
- Architectural

SHEET A10.03

LOWER STUDENT COMMONS

(4) DETAILS

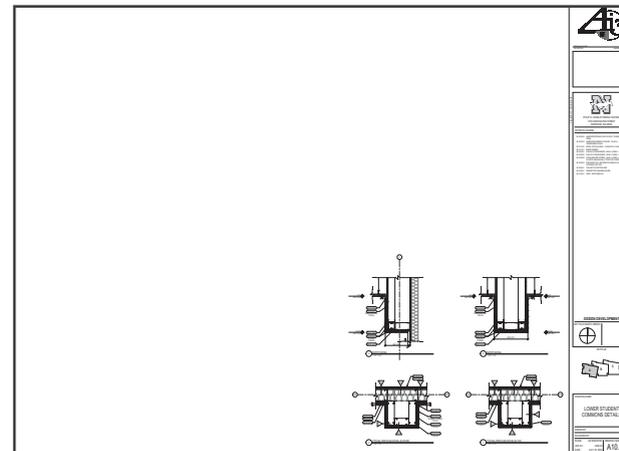

60% CD SUBMISSION



REPLACE WITH
ACOUSTIC CEILING TILE (ACT)

ADDITIONAL DRAWINGS SUBMITTED:

- Food Service
- Structure
- Fire Protection
- Plumbing
- Mechanical
- Electrical
- Technology
- Solar Design

SHEET A10.03

LOWER STUDENT COMMONS

(15) DETAILS

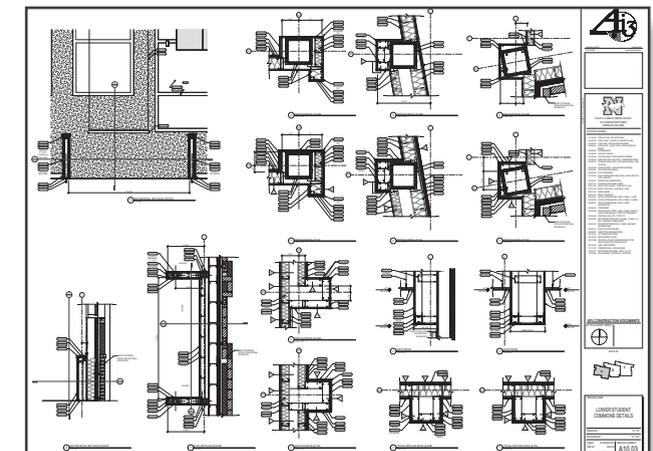

Project Update: SCHEDULE

THROUGH PROJECT COMPLETION

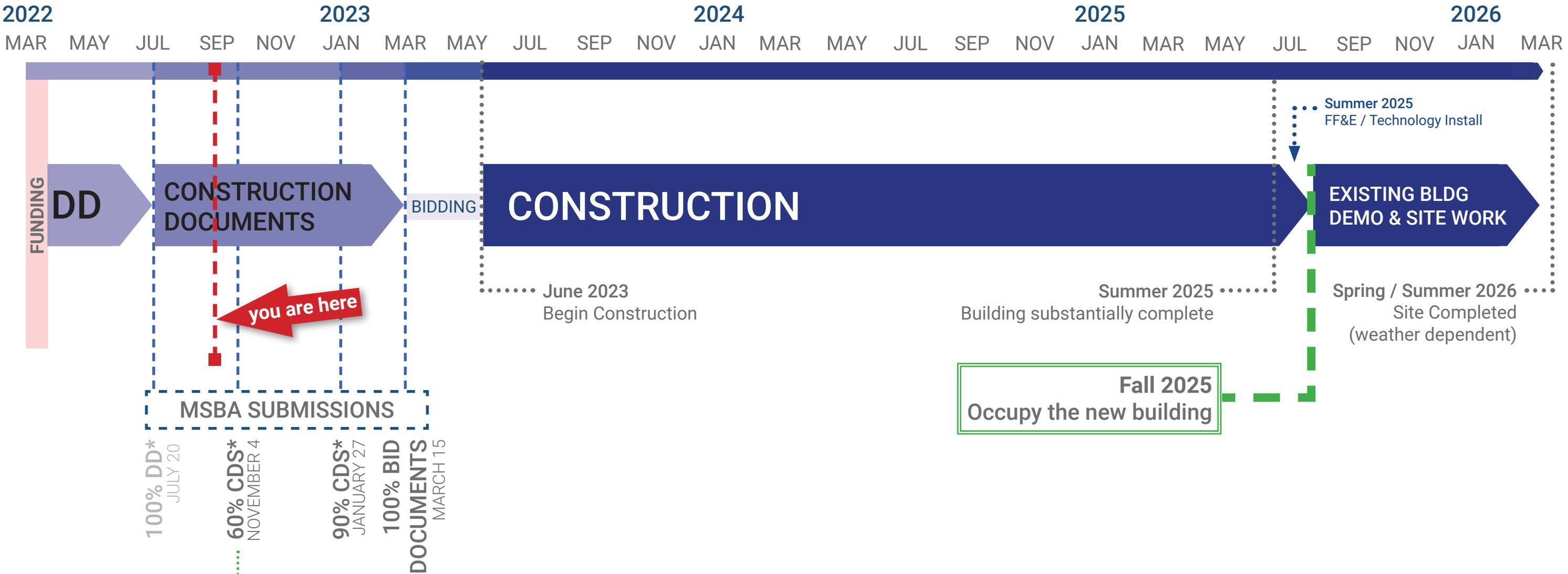

*Cost Estimates Required

COAKLEY
MIDDLE
SCHOOL

- 60% Estimating Documents
SEPTEMBER 21
 - 60% Estimate Reconciliation
OCTOBER 11-14
 - 60% CD MSBA Submission
NOVEMBER 4
- next step** (indicated by a red arrow pointing to the 60% Estimating Documents item)

DD = Design Development
CD = Construction Documents

Project Update: 60% CONSTRUCTION DOCUMENT SCHEDULE

SEPTEMBER

Sunday	Monday	Tuesday	Wednesday	Thursday	Friday	Saturday
				1	2	3
4	5	6	7	8	9	10
11	12	13	14	15	16	17
18	19	20	21	22	23	24
25	26	27	28	29	30	

MSBC

- SEPT 1 IDS KICK-OFF MTG WITH TEAM
- SEPT 8 MSBA DD TO 60%CD TRANSITION MEETING
- SEPT 21 DOCUMENTS OUT FOR ESTIMATING & REVIEW

OCTOBER

Sunday	Monday	Tuesday	Wednesday	Thursday	Friday	Saturday
						1
2	3	4	5	6	7	8
9	10	11	12	13	14	15
16	17	18	19	20	21	22
23	24	25	26	27	28	29
30	31					

MSBC

- OCT 11 ESTIMATES DUE
- OCT 13 ESTIMATE RECONCILIATION (TBD)
- OCT 17 MSBC MTG:
REVIEW ESTIMATES AND DISCUSS BUDGET MANAGEMENT
- OCT 24-28 STAFF MEETINGS - REVIEW SPACE & EQUIPMENT (TBD)
- OCT 24 **HOLD** MSBC MTG:
VOTE ON BUDGET MANAGEMENT ITEMS &
VOTE ON MSBC SUBMISSION

NOVEMBER

Sunday	Monday	Tuesday	Wednesday	Thursday	Friday	Saturday
		1	2	3	4	5
6	7	8	9	10	11	12
13	14	15	16	17	18	19
20	21	22	23	24	25	26
27	28	29	30			

MSBC

- NOV 4 MSBA SUBMISSION - 60% CD PHASE
- NOV 17 MTG WITH TOWN DEPARTMENTS (TBD)

INTERNAL SCHEDULE

- Monthly coordination meetings
- Weekly document sharing
- Live, real time, model updates

Accessibility
Acoustics
Commissioning
Control Systems
Building Code
Energy
OPM review

MSBA Submission Deliverables:

1. Drawings
2. Project Manual
3. Report



Next Middle School Building Committee meeting: October 17

